

Operating Instructions

Live Switcher

Model No. **AW-SW350P**

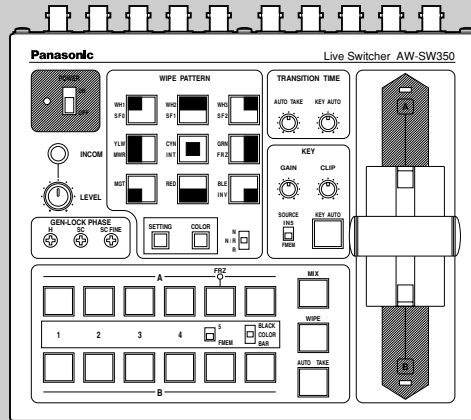

Panasonic®

Before attempting to connect, operate or adjust this product, please read these instructions completely.



CAUTION

**RISK OF ELECTRIC SHOCK
DO NOT OPEN**



CAUTION: TO REDUCE THE RISK OF ELECTRIC SHOCK,
DO NOT REMOVE COVER (OR BACK).
NO USER SERVICEABLE PARTS INSIDE.
REFER TO SERVICING TO QUALIFIED SERVICE PERSONNEL.



The lightning flash with arrowhead symbol, within an equilateral triangle, is intended to alert the user to the presence of uninsulated “dangerous voltage” within the product’s enclosure that may be of sufficient magnitude to constitute a risk of electric shock to persons.



The exclamation point within an equilateral triangle is intended to alert the user to the presence of important operating and maintenance (service) instructions in the literature accompanying the appliance.

WARNING:

TO REDUCE THE RISK OF FIRE OR SHOCK HAZARD, DO NOT EXPOSE THIS EQUIPMENT TO RAIN OR MOISTURE.

CAUTION:

TO REDUCE THE RISK OF FIRE OR SHOCK HAZARD AND ANNOYING INTERFERENCE, USE THE RECOMMENDED ACCESSORIES ONLY.

CAUTION:

TO REDUCE THE RISK OF FIRE OR SHOCK HAZARD, REFER CHANGE OF SWITCH SETTING INSIDE THE UNIT TO QUALIFIED SERVICE PERSONNEL.

Note:

The rating plate (serial number plate is on the bottom of the unit).

 indicates safety information.

FCC Note:

This device complies with Part 15 of the FCC Rules. To assure continued compliance follow the attached installation instructions and do not make any unauthorized modifications.

This equipment has been tested and found to comply with the limits for a class A digital device, pursuant to Part 15 of the FCC Rules. These limits are designed to provide reasonable protection against harmful interference when the equipment is operated in a commercial environment. This equipment generates, uses, and can radiate radio frequency energy and, if not installed and used in accordance with the instruction manual, may cause harmful interference to radio communications. Operation of this equipment in a residential area is likely to cause harmful interference in which case the user will be required to correct the interference at his own expense.

The information marking of this product may be found on the bottom of the unit. The serial number of this product may be found on the bottom of the unit. You should note the serial number of this unit in the space provided and retain this book as a permanent record of your purchase to aid identification in the event of theft.

Model No. _____

Serial No. _____

 indicates safety information.

CONTENTS

WARNING/CAUTION FOR SAFETY	5
PREFACE	6
FEATURES	6
PRECAUTIONS	7
MAJOR OPERATING CONTROLS AND THEIR FUNCTIONS	8
■TOP (CONTROL PANEL)	8
■REAR PANEL	15
IMAGE TRANSFER FUNCTION	20
■FUNCTIONS	20
■SPECIFICATIONS	21
■INSTALLING THE DEVICE DRIVER	22
■INSTALLING THE APPLICATION PROGRAM	25
■OPERATION METHOD	27
CONNECTIONS	32
■CONNECTION WITHOUT EXTERNAL SYNCHRONIZATION	32
■CONNECTION FOR EXTERNAL SYNCHRONIZATION	33
■CONNECTION TO PERSONAL COMPUTER	34
■EXAMPLE FOR THE CONNECTION WITH PAN/TILT HEADS AND CONTROL PANEL	36
RACK MOUNTING	38
■RACK MOUNTING	38
INFORMATION RELATED TO SYSTEM UPGRADES	39
SPECIFICATIONS/STANDARD ACCESSORIES	40
■SPECIFICATIONS	40
■STANDARD ACCESSORIES	41

WARNING/CAUTION FOR SAFETY

WARNING

- **Refer all servicing to qualified personnel**
To reduce the risk of electric shock, don't remove cover or back, unless you are a qualified personnel. Refer all mountings, connections, servicing to qualified service personnel.
- **No water or moisture inside**
Do not let water or moisture into the product, or expose it to moisture, to prevent a fire and electric shock.
- If you see smoke or smell an odor from the product, if water or other foreign matter gets inside, if it is damaged by dropping, or if you find anything wrong with it, immediately stop using it.
- **Do not disassemble or modify the product to prevent a fire and electric shock.**

CAUTION

- Do not drop the product, do not expose it to strong shock, or do not step on it, to prevent a fire and injuries.
- Do not install the product at a place full of moisture and dust, which may cause a fire and electric shock.
- Do not mount the Live Switcher on a closed rack or bookshelf. (Otherwise, heat will build up inside and may cause a fire.)
- Keep the ventilation port open to secure good flow of air.

PREFACE

The AW-SW350 has five video inputs, wipe, mix and key synthesis functions despite its compact dimensions. Since it has a built-in frame synchronizer, it accepts the input of asynchronous signals. Moreover, it enables systems to be configured using the black burst signals which it outputs, and it supports external synchronization (or genlock) to external sync signals as well. Its image transfer function enables the images and text created using a personal computer to be captured in the switcher through its USB port. The switcher can be used in the field because it operates on an external power supply (12 V DC) while its tally outputs and intercom inputs/outputs permit easy system configuration.

FEATURES

- **Five Inputs Despite Compactness**

The switcher has five composite video signal inputs. (Automatic termination. Loophrough output provided) It also has an S-terminal (4-pin), and can thus handle YC signals. Input 5 can be switched to the internal frame memory or vice versa by means of a switch. Internal black or color signal (9 patterns) can be selected.

- **Three Program Outputs, Preview Outputs Available**

Effect outputs including two composite video outputs (BNC connectors) and one YC signal output (S-terminal, 4-pin) are available, so it is easy to build a system with monitors, VCRs, etc. The AW-SW350 also features the Preview output to confirm the next operation. (Look Ahead Preview)

- **Frame Synchronizer System and Genlock System Supported**

The switcher contains a high-performance 10-bit frame synchronizer: this means that asynchronous signals can be directly input to the input camera or other such device without having to initiate genlock. Its inputs are equipped with a frame synchronizer function so that its images are do not freeze even when the frames are switched. Alternatively, the frame synchronizer can be turned off, genlock can be applied to a camera or other such device, and the unit can be used as a wideband switcher with minimal deterioration in image quality (resolution of 800 lines).

- **Genlock**

The switcher enables genlocking to the reference sync signal of an external device. Furthermore, by using its BB output, the system can be upgraded using the synchronization of the switcher as a reference.

- **Image Transfer, Soft Keys and Linear Keys**

Inside the switcher AW-SW350 has a 1-frame frame memory so that the images created using a personal computer can be captured in this memory through the USB port. There are nine different patterns for wipe, and one of three softness levels can be set. Text can also be synthesized smoothly by performing linear key operations.

- **External Power Supply**

The switcher can be used both indoors and outdoors because it operates on an external power supply of 12 V DC. (However, it is not built rainproof or dripproof. Do not expose the switcher to rains or moisture.)

- **Tally and Intercom Provided**

Five tally outputs and five intercom inputs and outputs are available so that the switcher can be directly apply to conventional systems. (The switcher has its own intercom on the panel.)

PRECAUTIONS

- **Handle with Care.**

Do not drop the switcher, or expose it to strong shock or vibration. This is important to prevent trouble and accidents.

- **Operating temperature range 32F to 104F**

Avoid using it in a cold place below 32F or a hot place above 104F because low or high temperature will adversely affect the parts inside.

- **Switch power off before cables connection or disconnection.**

Be sure to switch power off before connecting or disconnecting the cables.

- **Use at a Place Not Humid, Not Dusty.**

Avoid using the switcher at a humid, dusty place because the internal parts are subject to damage by moisture and dust.

- **Care**

Switch power off and wipe the switcher with a dry cloth. If it is difficult to remove the dirt, dip a cloth into a diluted solution of kitchen detergent, squeeze it hard, and wipe the product carefully.

Note

- Do not use benzine, paint thinner, or other volatile liquids.
- When using a chemical duster, carefully read the caution notes on its use.

MAJOR OPERATING CONTROLS AND THEIR FUNCTIONS

TOP (CONTROL PANEL)

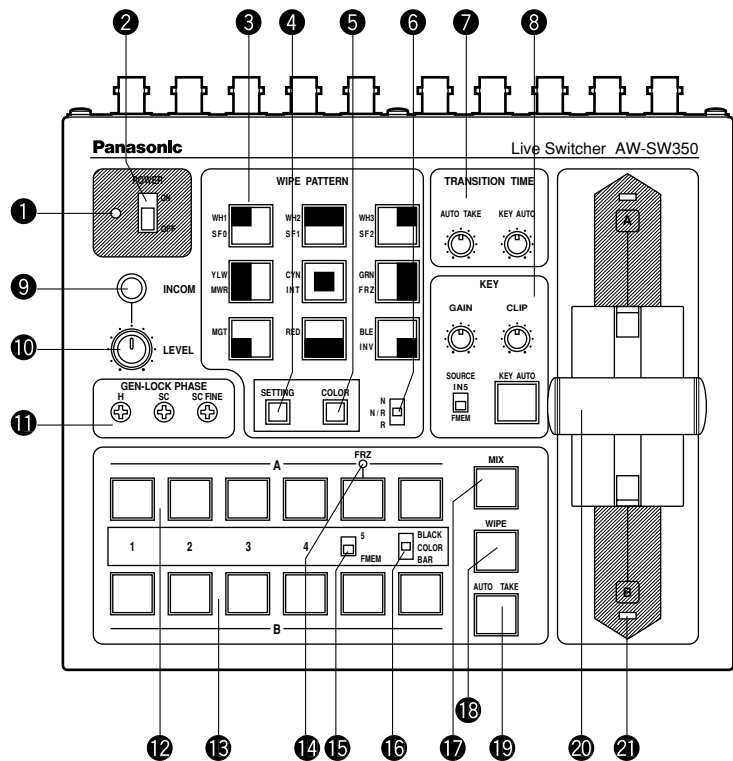

1 Power Indicator [POWER]

Lights (green) when power is supplied to DC Power Input Terminal ③ and Power Switch ② set to the ON position, and goes out when Power Switch ② is set to the OFF position.

2 Power Switch [POWER ON/OFF]

Power is switched on and Power Indicator ① lights when this switch is set to the ON position, provided that power is supplied to DC Power Input Terminal ③. Power is switched off and Power Indicator ① goes out when the switch is set to the OFF position.

Caution

Even when the Power Switch is at the OFF position, some of the power supply circuits are still operating. To turn off the power completely, set the external power adaptor to OFF.

3 Wipe Pattern Selection Switches [WIPE PATTERN]

To select a wipe pattern after pressing Wipe Switch ⑱. One of the nine patterns can be selected. The selected switch lights.

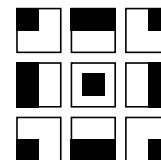

4 Setting Switch [SETTING]

This functions as the shift key for the wipe patterns. While it is held down, the Wipe Pattern Selection Switches can select the functions described below. The functions are indicated with blue characters.

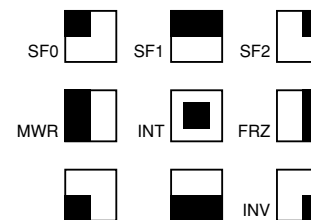

SF0, SF1, SF2: These are used to set the three wipe softness levels.

The minimum softness level is set by SF0 (a hard key), and the maximum softness level is set by SF2.

MWR: This makes it possible for the user to set the initial statuses of the panel when the power is turned on.

First, set the statuses of the panel to be recorded. Once the setting has been performed, keep pressing MWR while holding down the SETTING switch until the nine switches go off. The recorded statuses will be reproduced when the power is next turned on.

INT: This is used to restore the initial settings which were established at the factory.

Keep pressing INT while holding down the SETTING switch until the nine switches go off. The same statuses as the factory setting statuses will be established when the power is next turned on.

FRZ: This is used to set the freezing of the Video Input 5 signal to ON or OFF. When FRZ is pressed while holding down the SETTING switch, the Video Input 5 signal is frozen. While the signal is frozen, the FRZ ⑭ LED lights. This signal can be used as the source of the VIDEO IN 5 signal.

*If the freeze function is used while the FS switch is in the OFF position, only the Video Input 5 signal will be set to the FS ON status.

INV: This is used to invert the polarity of the key signal.
 Use the inversion mode when the input is black text on a white base.
 When the INV function is used with VIDEO IN 5 selected for the key source and with the FS switch in the OFF position, only the Video Input 5 signal will be set to the FS ON status.

5 Color Background Color Selector Switch [COLOR]

This functions as the shift key of the Wipe Pattern Selection Switches. While it is pressed, the Wipe Pattern Selection Switches can select the color to be used for the color background, as shown below. The functions are indicated with red characters.

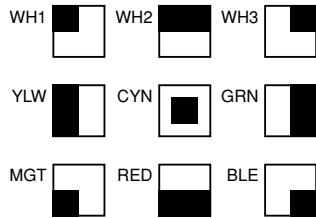

WH1: White 100% WH2: White 90% WH3: White 80%
 YLW: Yellow CYN: Cyan GRN: Green
 MGT: Magenta RED: Red BLE: Blue

6 Wipe Direction Selection Switch [N/ N/R/ R]

To select one of the three directions in which to change the signals from A to B or vice versa on the screen by moving Fader Lever 20.

N (Normal):

When Fader Lever 20 is moved from A to B, the image is switched from the selected A-bus signal to the selected B-bus signal in the direction of the black to white pattern shown on Wipe Pattern Selection Switch. Similarly, when Fader Lever 20 is moved from B to A, the image on the screen is switched from the selected B-bus signal to the selected A-bus signal.

R (Reverse):

When Fader Lever 20 is moved from A to B, the image is switched from the selected A-bus signal to the selected B-bus signal in the direction of the white to black pattern shown on Wipe Pattern Selection Switch. Similarly, when Fader Lever 20 is moved from B to A, the image on the screen is switched from the selected B-bus signal to the selected A-bus signal.

N/R (Normal/Reverse):

When Fader Lever 20 is moved from A to B, the image is switched from the selected A-bus signal to the selected B-bus signal in the direction of the black to white pattern shown on Wipe Pattern Selection Switch. When Fader Lever 20 is moved from B to A, the image on the screen is switched from the selected B-bus signal to the selected A-bus signal.

[Example] Selected wipe pattern

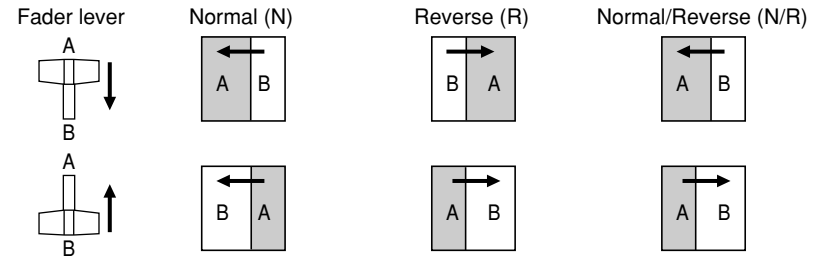

7 Transition Time Setting Controls [TRANSITION TIME]

These controls are used to set the transition time during auto fader operations.

AUTO TAKE: This is used to set the transition time of MIX or WIPE when the AUTO TAKE 19 Switch has been pressed. Any transition time from 0 to about 10 seconds can be set.

KEY AUTO: This is used to set the transition time when the KEY AUTO 6 Switch has been pressed. Any transition time from 0 to about 5 seconds can be set.

Turning either control knob counterclockwise reduces the transition time; conversely, turning them clockwise increases the transition time. When either control knob is turned counterclockwise as far as it will go, the transition time is set to 0 seconds, and the cut operation results. Even when external takes are performed using external switches, the settings of these controls remain in force. (When a switch has been connected to EXT TAKE 30)

Caution

Before proceeding with auto fader operations, set the transition times in advance using these controls.

8 Key Synthesis Setting Controls [KEY]

These are used to perform the settings relating to key synthesis.

GAIN, CLIP: The AW-SW350 features a linear key system for key synthesis to ensure smooth synthesis, and these two controls are used to set the synthesis levels when text and other data are to be synthesized with the key signals. The CLIP control is for setting the reference level at which the key signals are to be created, and signals above this level are synthesized. If noise is present in the background images, set the CLIP level on the high side. The GAIN control is for raising or lowering the level of the key signals. Adjust it in such a way that the text, etc. can be synthesized cleanly and clearly.

[Example of adjustment]

Turn the CLIP control counterclockwise as far as it will go and, while viewing the screen, adjust the GAIN control to achieve clean and clear images. Next, adjust the CLIP and GAIN controls alternately to set to the optimum state.

KEY AUTO: This switch is used to set the key synthesis to ON or OFF. When it is pressed, it lights, and key synthesis is performed for the text, etc. KEY AUTO ⑦ is used to set the transition time for the key synthesis. When the switch is pressed again, it goes off, and the input signals used for the key synthesis will be synthesized as they are with the base image but, depending on the level of the input signals, it may not be possible to achieve clean and clear images.

SOURCE: This selects whether to use the VIDEO IN 5 signal or image in the frame memory as the source material for the key synthesis. In terms of the key signals, use black base level signals, and provide a source with white characters. A source with color characters can also be synthesized with a black base but, depending on the level of the character signals, it may not be possible to achieve clean and clear images. (By inverting the polarity of the key signals, images with a white base level can also be synthesized. For details on key reversal, refer to SETTING ④.)

Note

Follow the procedure below to keep the key synthesis on the PVW screen at the OFF setting at all times.

1. Press both the SETTING Button ④ and COLOR Button ⑤ at the same time.
2. With the two buttons in step 1 held down, press the KEY AUTO Button. The KEY AUTO Button lamp now lights.

To turn the key synthesis on the PVW screen back to the ON setting, repeat the same steps. The KEY AUTO Button lamp will then go off.

⑨ Intercom Jack [INCOM]

Connect an intercom headset to this terminal. Use the recommended headset (made by Ashida Onkyo MT-12MFB-03).

⑩ Intercom Volume [INCOM LEVEL]

To adjust the volume of the headset speaker connected to Intercom Jack ⑨. Turning it counterclockwise decreases the volume, and turning it clockwise increases it.

⑪ Genlock Phase Controls [GEN-LOCK PHASE]

Connect a signal generator or other such instrument to GLIN/BBOUT ⑳, and use these controls to adjust the phase when genlock is to be initiated. These controls need not be adjusted when genlock is not going to be initiated.

H: This is used to adjust the horizontal sync phase.

SC: This is used to adjust the subcarrier phase coarsely.

SC FINE: This is used to adjust the subcarrier phase finely.

Adjusting the horizontal phase:

Monitor the waveforms of the genlock signal (black burst signal) and video signal output using a dual-trace oscilloscope (or waveform monitor), and adjust the H Control in such a way that the horizontal phase is aligned.

Adjusting the subcarrier phase:

Select the color bars of the switcher. Using the signal generator as a reference, adjust the SC Control and SC FINE Control to align the color phase. A more accurate adjustment can be achieved using a vectorscope.

⑫ A-Bus Input Selection Switches

To select A-bus video signals. When a switch is pressed, it lights and indicates that the corresponding signal is selected.

⑬ B-Bus Input Selection Switches

These are used to select the B-bus video signals. When a switch is pressed, it lights to indicate that the corresponding signal is selected.

Depending on the operation mode, the switches may light with full or half brightness.

Full brightness: When the selected input is being output to PGM OUT.

Half brightness: When the switch is selected but the selected input is not being output to PGM OUT.

[Example] When the Fader Lever is at the A-bus side, the A-bus signals are output so that the A-Bus Input Selection Switches will light with full brightness, but the B-bus signals are not output so that B-Bus Input Selection Switches will light with half brightness.

⑭ Freeze indicator [FRZ]

This LED lights to indicate that the VIDEO IN 5 signal is frozen. Bear in mind that since the image remains frozen while it is lighted, the switcher output will not change even when the input signal has changed.

⑮ Input 5/FMEM Selector Switch [FMEM]

This is used to select the signal which has been input to VIDEO IN 5 or the internal frame memory. When the switcher is used for the first time and the frame memory has been selected, the factory setting screen is output. By transferring image data from a personal computer to the frame memory, the images and text created by the user can be output. For details, refer to the page on which image transfer is described.

⑯ BLACK/COLOR/BAR Selector Switch [BLACK/COLOR/BAR]

This is used to select BLACK (black level signal), COLOR (color background) or BAR (color bar). When COLOR is selected, one of nine colors can be selected. For details on how to select the color, refer to the section on "⑤ Color Background Color Selector Switch [COLOR]".

A 100% white signal is output at the factory setting.

17 Mix Switch [MIX]

Press it to switch the signal selected with A-Bus Input Selection Switch 12 to the signal selected with B-Bus Input Selection Switch 13 or vice versa by the mix effect. The switch lights when MIX is selected.

18 Wipe Switch [WIPE]

Press it to switch the signal selected with A-Bus Input Selection Switch 12 to the signal selected with B-Bus Input Selection Switch 13 or vice versa by the wipe effect. The switch lights when WIPE is selected.

19 Auto Take Switch [AUTO TAKE]

This switch is used for automatically wiping or mixing instead of performing these operations manually using the Fader Lever 20. This switch becomes operational when the Fader Lever 20 is set all the way toward the A or B side, and when it is pressed once, the wipe or mix operation is performed automatically. The transition time for switching the signals can be adjusted using the AUTO TAKE 7 control. While the signals are being switched, the AUTO TAKE switch lights, and it goes off when the signals are switched completely. During an auto take operation, no manual operations will be performed even if the Fader Lever 20 is moved.

Caution

In using the Auto Take function, be sure to move Fader Lever 20 all the way to A or B. Auto Take will not work unless the lever is fully moved to A or B.

20 Fader Lever [A/B]

This lever is used to switch the signal selected with A-Bus Input Selection Switch 12 to the signal selected with B-Bus Input Selection Switch 13 or vice versa by the wipe or mix effect. When the lever is moved from A to B, the video signal is also switched from A to B accordingly. Similarly, when the lever is moved from B to A, the video signal is switched from B to A.

21 Bus Tally Indicators [A], [B]

These indicate the output statuses of the A-bus and B-bus. The [A] or [B] LED lights to indicate that A-bus or B-bus signals are being output.

[Examples]

- [A] lights when the Fader Lever is at the A side since only the A-bus signals are output.
- Both [A] and [B] light when the Fader Lever is between the A and B sides since both A-bus and B-bus signals are output.

Note

Bus control based on the flip-flop system is enabled by changing the setting of the bus selector switch [BUS A/B /F.F.] 4 which is one of the Setup Switches 32. Under the flip-flop system, the signals selected by the A-Bus Input Selection Switches 12 are always selected as the program (PGM) video signals, and the signals selected by the B-Bus Input Selection Switches 13 are always selected as the preview (PVW) video signals. Furthermore, the PGM signals can be replaced with the PVW signals or vice versa by means of bus switching using the AUTO TAKE Switch 19 and Fader Lever 20.

REAR PANEL

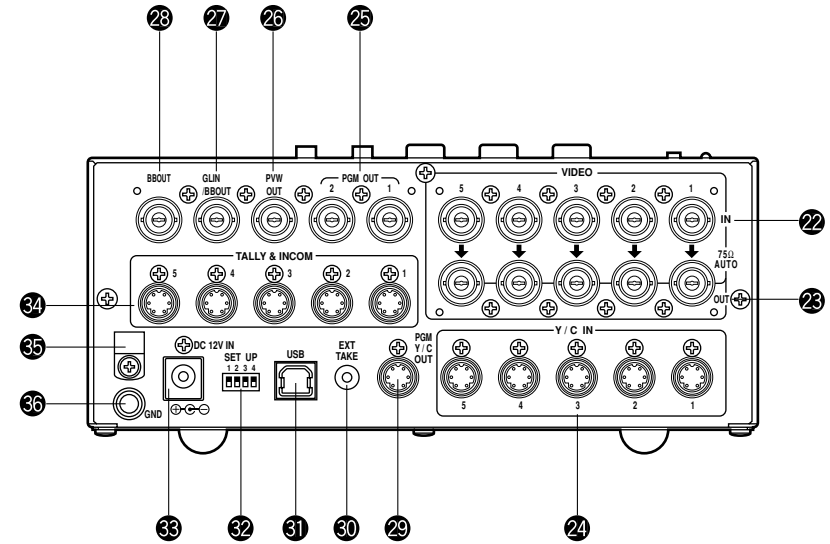

22 Video Signal Input Jacks 1 to 5 [VIDEO IN 1, 2, 3, 4, 5]

These jacks are to input composite video signals. (1 Vp-p, 75-ohm auto-terminated)
There are 5 input jacks corresponding to A-Bus Input Selection Switches 12 and B-Bus Input Selection Switches 13.

Caution

If a BNC coaxial cable is connected to Video Signal Loopthrough Output Jack 23, the 75-ohm termination is automatically released. Do not connect a BNC coaxial cable to any of these jacks in case of connecting YC signals to Y/C Signal Input Jack 24. Use either composite signals or YC signals as video input signals. Furthermore, when unstable video signals from a VHS format VCR, DVD player or other device have been input, the frame synchronizer may malfunction.

23 Video Signal Loopthrough Output Jacks [VIDEO OUT 1, 2, 3, 4, 5]

These loopthrough output jacks are for the composite video signals input to Video Signal Input Jacks 22.

24 Y/C Signal Input Jacks [Y/C IN 1, 2, 3, 4, 5]

Connect YC signals to these jacks in using them as video input signals.

Caution

Do not connect a BNC coaxial cable to Video Signal Input Jack 23 in case of connecting YC signals to Y/C Signal Input Jack 24. Use either composite signals or YC signals as video input signals.

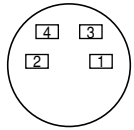

Pin No.	Signal
1	Y GND
2	C GND
3	Y
4	C

25 Video Output Connectors [PGM OUT 1, 2]

Two sets of composite signals (BNC) consisting of the switcher's main output together with the wipe, mix, key or other effects added are output from these output jacks.

26 Preview Output Connector [PVW OUT]

When the switcher is used for live applications, this connector enables the next operation to be previewed. (LOOK AHEAD PREVIEW)

- While the Fader Lever is at the A-bus side and A-bus signals are output, the B-bus signals are output to the PVW OUT Connector, and the images can be previewed.
- When the PGM OUT Connectors are in the key OFF status, the PVW OUT Connector is set to the key ON status and the key synthesis status can be previewed.

The table below shows the correlation between the program output and preview output statuses.

	Bus selection		Key ON/OFF	
	A-bus selected	B-bus selected	Key ON	Key OFF
PGM OUT	A-bus selected	B-bus selected	Key ON	Key OFF
PVW OUT	B-bus output	A-bus output	Key OFF	Key ON

27 Genlock Input/BB Output Connector [GLIN/BBOUT]

In compliance with the setting of the SETUP switch 32, either the genlock input or BB output is selected.

Genlock input: To apply genlock to the switcher, connect this signal to the signal generator or other device.

BB output: At this position, the BB sync signal is output to apply genlock to a camera or other input device by synchronizing it to the switcher. In this case, the same signal as BBOUT 28 is output.

28 Black Burst Signal Output Connector [BBOUT]

Used to externally synchronize a input device connected to the Live Switcher. When externally synchronizing two or more devices, distribute the black burst output to them using a video distributor (VDA).

29 Y/C Video Output Connector [PGM Y/C OUT]

This connector delivers the Y/C signal video output which has the same function as the video output signal 25.

Caution

Due to what is involved in the signal processing, the Y/C video output 29 has a phase which is delayed by 1 line compared with the composite video output 25.

30 Auto Take External Input Jack [EXT TAKE]

Use it for external auto take by applying a contact input. The operation is the same as when using Auto Take Switch 19 and Key Auto Switch 8.

*Use an M3.5 stereo single head plug for connection with this unit.

Connect the switches as shown below.

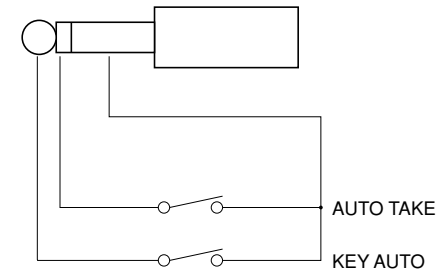

31 USB port [USB]

Connect one end of the USB cable to this port and the other end to the personal computer to transfer the image data created by the personal computer to this switcher. For details, refer to the page on which image transfer is described.

32 Setup switches

These are used to perform the following four settings.

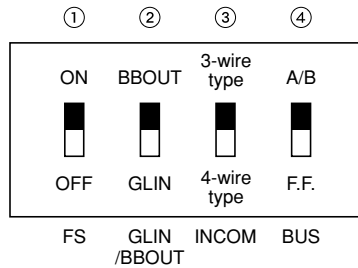

1 Frame Sync Switch [FS ON/FF]

This sets the frame synchronizer to ON or OFF.

ON: The asynchronous 5 input signal can be connected. A delay of up to one frame is generated in the switcher output. Due to what is involved in the signal processing, the signal band is narrower than at the OFF position.

OFF: The input signal source must be synchronized with the system. Use the switcher's black burst signal output to apply genlock to the camera or other device. In this case, perform the phase (horizontal phase, color phase) adjustments for the genlock at the connected device. In this mode, analog processing is performed internally, and there is virtually no deterioration in the image quality.

2 Genlock input/Black burst output setting [GLIN/BBOUT]

This sets the input or output for the GLIN/BBOUT Connector 27.

GLIN: Set here when genlocking the switcher with an external sync signal.

GLIN/BBOUT 27 now serves as an input connector, and an external sync signal can be connected.

BBOUT: Set here when configuring a system based on the synchronization to the switcher. GLIN/BBOUT 27 now serves as an output connector, and a black burst signal is output. In this case, the output is the same as the BBOUT 28 signal.

3 Intercom Switch [INCOM 3/4]

The 3-wire or 4-wire type can be selected by setting the switch to the position appropriate to your system.

(Set the switch to the 3-wire position if you are using the WV-RC700A or WV-RC550.)

4 Bus Selector Switch [BUS A/B /F.F.]

This selects the bus switching system.

A/B: Set here when undertaking bus operations using the A/B bus system.

F.F.: Set here when undertaking bus operations using the flip-flop system.

33 DC Power Input Terminal [DC 12V IN]

Apply 12-V DC power. (Use the AC adaptor AW-PS505.)

*The AW-CA4T1 cable (sold separately) is required.

Caution

If you are using other power supply, make sure that it outputs 12 V DC, 2.5 A or more. The plug has GND on the inside and +12 V outside. (Be careful of the positive and negative polarities.)



34 Tally/Intercom Connectors [TALLY & INCOM 1, 2, 3, 4, 5]

Use these jacks to connect the Live Switcher to the tally/intercom connectors on a camera control unit, for example, WV-RC700A or WV-RC550, for tally control and intercom communication. Tally control is based on open collector output. These connectors are compatible with either the 3-wire or 4-wire type of intercoms, selectable with Setup Switch 32.

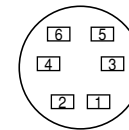

Pin No.	Signal
1	MIC+
2	MIC-/COMMON
3	PHONE+
4	PHONE-/COMMON
5	TALLY
6	GND

35 Cord Clamp

Used to clamp the cable connected to the DC power input terminal to prevent its disconnection. Once remove the screw, pass the cable, and retighten the screw till the cable is securely clamped.

36 Ground Terminal [GND]

Connect this to the system frame ground.

IMAGE TRANSFER FUNCTION

The AW-SW350 Live Switcher comes with a function for transferring images from the host computer using the USB (Universal Serial Bus). The image data transferred from the host computer can be used as the key input signals or main input signals of the AW-SW350. When the image transfer function is to be used for the first time, the dedicated device driver and application program must be installed in the host computer. They can be installed from the CD-ROM that is supplied with the AW-SW350. For details on how to install them, refer to “Installing the Device Driver” and “Installing the Application Program”.

FUNCTIONS

The USB image transfer program used with the AW-SW350 contains the following functions.

- Frame memory image transfer function (RAM)
- Flash memory image transfer function (ROM)
- Image cutout position designation function
- Image start position designation function

For more details on how to use these functions, refer to “Operation Method”.

SPECIFICATIONS

In order for the host computer to run the USB image transfer program used with the AW-SW350, it must satisfy the following system requirements.

Processor	Pentium III, 1 GHz or up recommended
RAM	128 MB or more
Free hard drive memory	50 MB or more
Operating system	Windows 98 Second Edition (SE), Windows Me, Windows 2000, Windows XP
USB port	USB Version 1.1 or up
CD-ROM drive	Essential

Image files in two formats, the bitmap format (bmp) and JPEG format (jpg, jpeg), can be used with the USB image transfer program for the AW-SW350. Also required separately when using the image transfer function is the A-B type USB cable for connecting the host computer with the AW-SW350.

Caution

More time is required to transfer the images if the performance of the personal computer is low-level. The function will not work with versions of Windows that are not recommended (Windows 3.1, Windows 95, Windows 98, Windows NT4.0). Pentium is a registered trademark of Intel Corporation. Windows, Windows 98, Windows Me, Windows 2000 and Windows XP are registered trademarks of Microsoft Corporation.

■ INSTALLING THE DEVICE DRIVER

This section describes how to install the device driver used with the USB image transfer program for the AW-SW350. In the example of the procedure given below, Windows XP is used as the operating system.

1 Insert the CD-ROM supplied with the AW-SW350 in the CD-ROM drive of the host computer. (In this example, E: is the drive used.)

2 Set the AW-SW350's Power Switch to ON, check that the Power Indicator has lighted, and connect one end of the A-B type USB cable to the USB port on the rear panel of the AW-SW350 and the other end to the USB port on the host computer. (Fig.1)

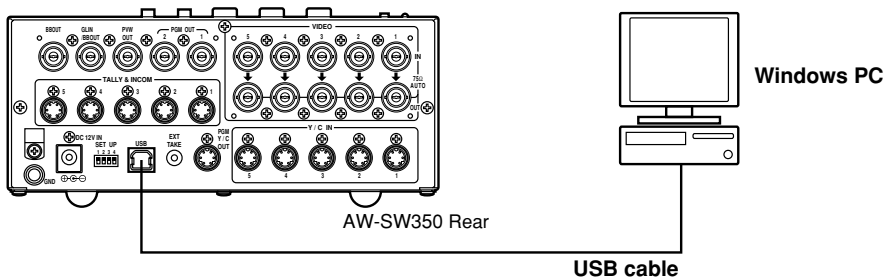

Fig.1 Connections

3 When the host computer recognizes the AW-SW350, as shown in Fig.2, the Found New Hardware Wizard automatically starts up.



Fig.2 Found New Hardware Wizard start screen

4 When the screen for specifying the driver loading directory appears as shown in Fig.3, specify the \DRIVER folder of the drive where the CD-ROM supplied with the AW-SW350 was inserted, and load the driver. (In this example, E: is the drive used.)



Fig.3 Driver specification screen

5 When the device driver has been loaded, a screen similar to the one shown in Fig.4 appears. This completes the installation of the device driver.



Fig.4 Driver loading completion screen

- 6** In order to confirm that the device driver has been installed successfully, it is recommended that you open the Device manager as shown in Fig.5, and check that “AW-SW USB Device:AW-SW350” is displayed.

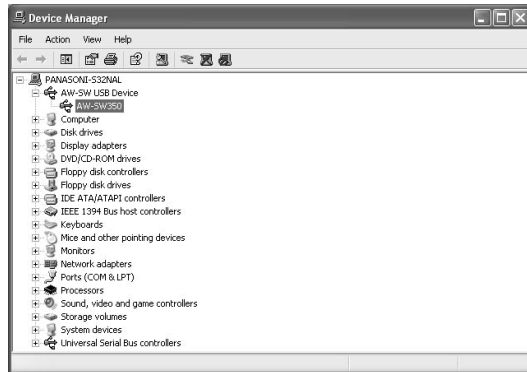

Fig.5 Device manager screen

■INSTALLING THE APPLICATION PROGRAM

This section describes how to install the application program used with the USB image transfer program for the AW-SW350. In the example of the procedure given below, Windows XP is used as the operating system.

- 1** Insert the CD-ROM supplied with the AW-SW350 in the CD-ROM drive of the host computer. (In this example, E: is the drive used.)
- 2** Run the “Microsoft .Net Framework” setup file (E:\JPN\DOTNETFX.EXE).
- 3** The installer program shown in Fig.6 now starts. Proceed with the installation by following the installer instructions.

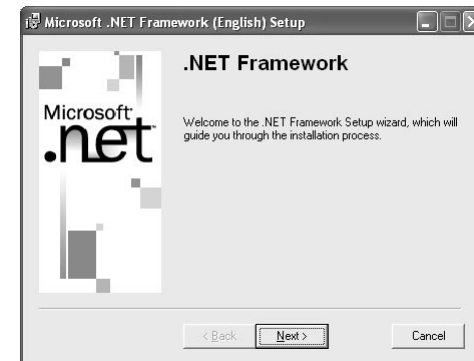

Fig.6 Microsoft .Net Framework installer start screen

- 4** Run the setup program (E:\JPN\SETUP.EXE).

- 5** The installer program shown in Fig.7 now starts. Proceed with the installation by following the installer instructions.



Fig.7 Application program installer start screen

- 6** This completes the installation of the application program.

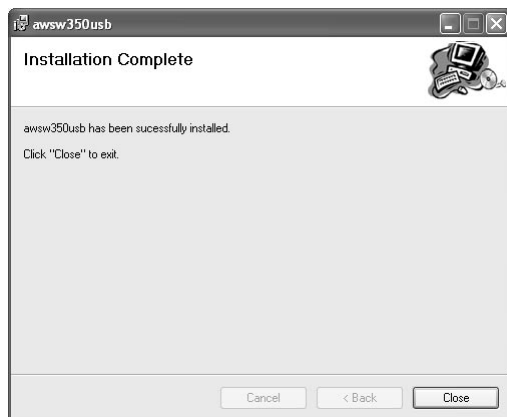

Fig.8 Application program installation completion screen

■ OPERATION METHOD

This section describes how to operate the application program used with the USB image transfer program for the AW-SW350.

- 1** Connect the host computer to the AW-SW350.
(Check that the AW-SW350's power is on.)
- 2** The main screen shown in Fig.9 appears when the application program used with the USB image transfer program for the AW-SW350 is started up.

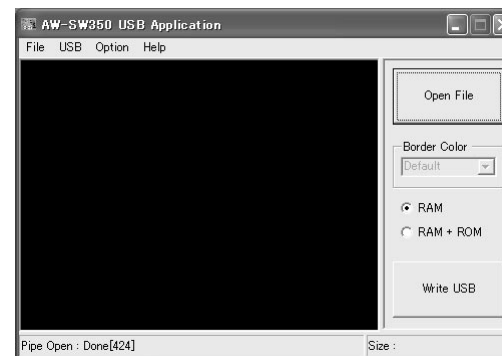

Fig.9 Application program main screen

- 3** When the "Open File" button is clicked, the file selection dialog box shown in Fig.10 appears. Select the image file (BMP, JPG or JPEG) to be transferred, and click "OK".

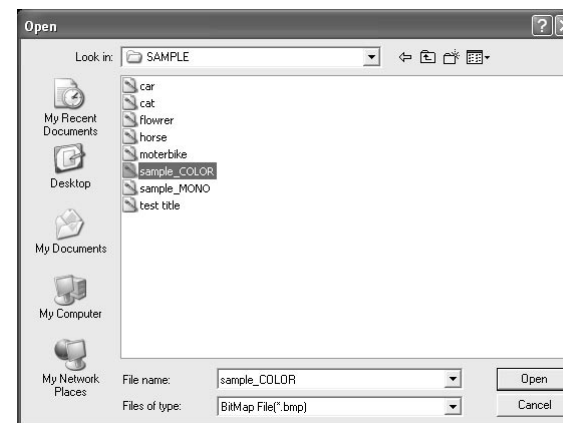

Fig.10 File selection dialog box

4 When the target image appears in the image display area, specify the start or cutout position of the image. Which position is to be specified is determined by the number of pixels in the image file.

- No. of pixels that can be displayed: 720 (H) x 487 (V)
- When the file is smaller than the number of pixels that can be displayed:
The spaces around the image are displayed in black. Move the image to the position where it is to be displayed.
- When the file is larger than the number of pixels that can be displayed:
The frame outlining what can be displayed appears. Move the frame to the position where the image to be displayed is framed.

<When the image is smaller than the number of pixels that can be displayed>

Drag the image displayed in the screen display area and drop it to change its position. (Fig.11)

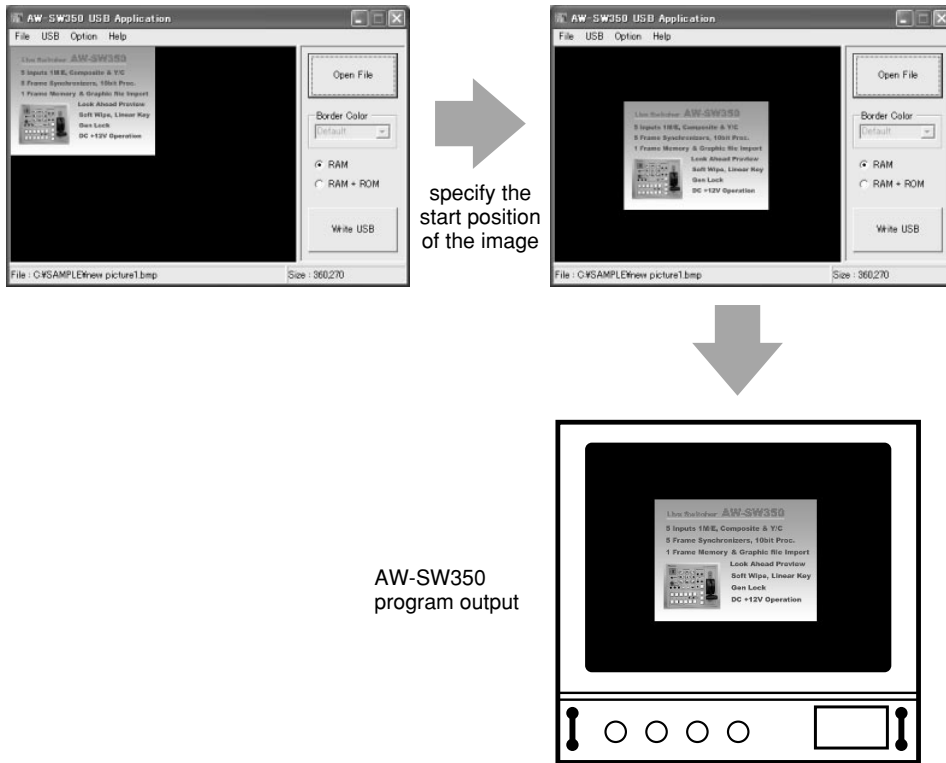

Fig.11 Specifying the image start position

<When the image is larger than the number of pixels that can be displayed>

Drag the frame displayed in the screen display area and drop it to change the cutout position. (Fig.12)

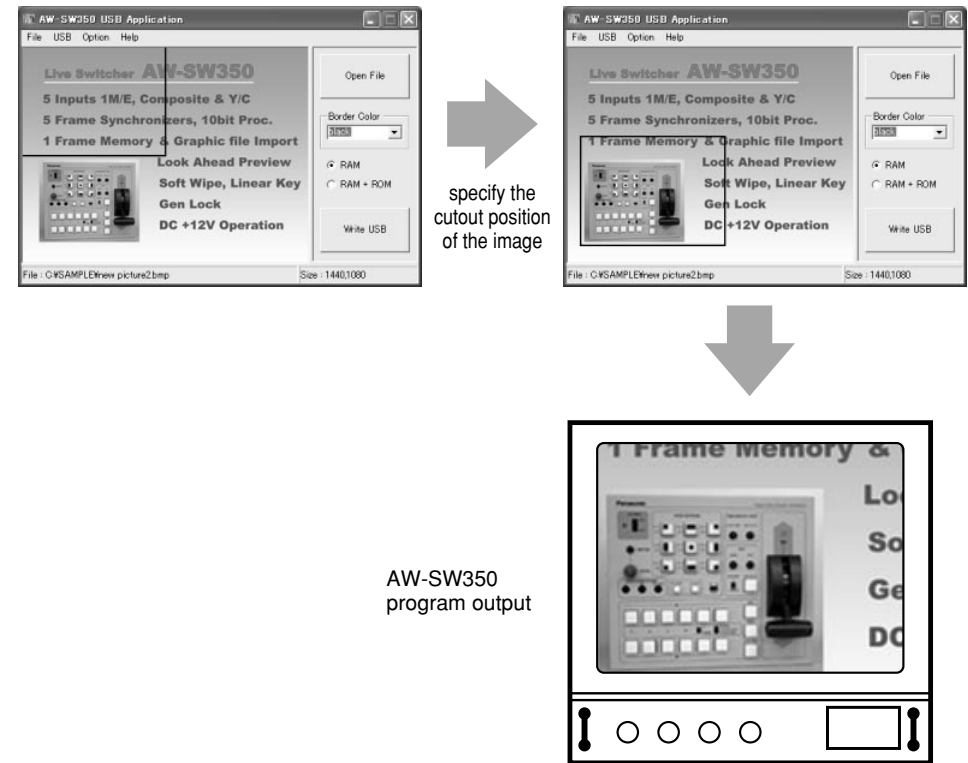

Fig.12 Specifying the image cutout position

5 Click the “RAM” radio button or “RAM+ROM” radio button to select the type of memory in which the data will be saved. (Fig.13) If “RAM” is selected, the image data is saved only in the frame memory and so it cannot be used after the AW-SW350 power has been turned off and back on again. If “RAM+ROM” is selected, the image data is saved in the flash memory and so it can be used after the AW-SW350 power has been turned off and back on again. However, the actual transfer takes longer than when “RAM” is selected.

	Status after power has been turned off and back on again	Transfer time
RAM	Transferred image data cannot be used	Approx. 10 sec.
RAM+ROM	Transferred image data can be used	Approx. 60 sec.

*The transfer times given in the above table are approximations only. The actual time taken will depend on the performance of the host computer.

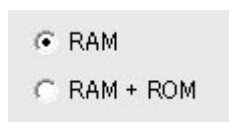

Fig.13 Memory selection

6 Click the “Write USB” button to start transferring the image data. After the completion of the transfer, monitor the AW-SW350’s PGM output and check that the image data has been transferred. (Fig.14)

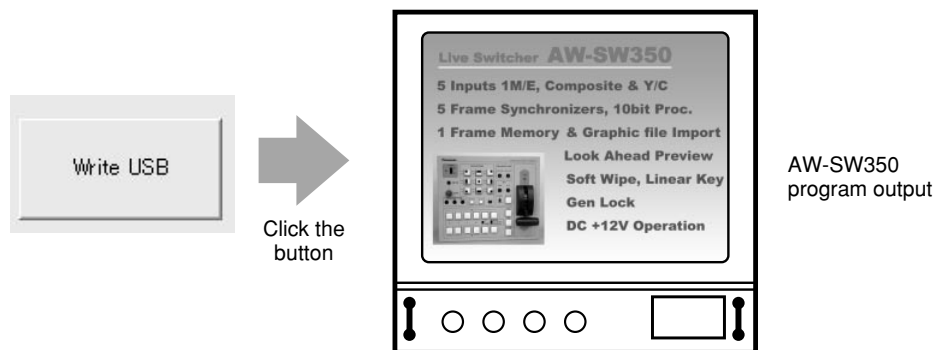

Fig.14 PGM check

— When images could not be transferred —

If an error resulted or images could not be transferred because a cable was connected or disconnected, turn off the switcher's power and exit the application program. Then turn the switcher's power back on again and start up the application again.

CONNECTIONS

- For installation and connection, be sure to ask the store where you purchased the product.
- Before making any connection, switch off all the components of the system.
- Carefully read the manuals for the individual devices connected to the Live Switcher.
- Use coaxial cable to connect video and genlock signals.

CONNECTION WITHOUT EXTERNAL SYNCHRONIZATION (Frame Synchronizer ON)

Caution

When unstable video signals, such as those from a VCR, are being used for the input signals, the internal frame synchronizer may not operate correctly.

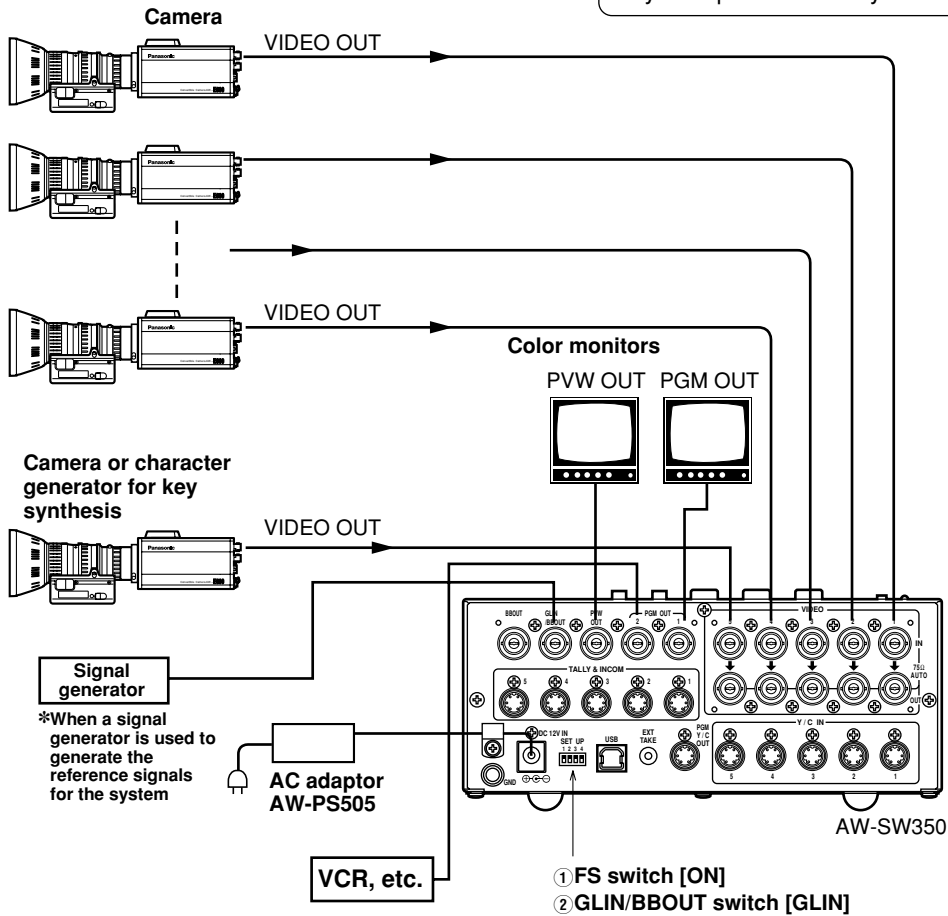

CONNECTION FOR EXTERNAL SYNCHRONIZATION (Frame Synchronizer OFF)

- Adjust the horizontal and color phases of the cameras.
(Read the manual for the camera.)

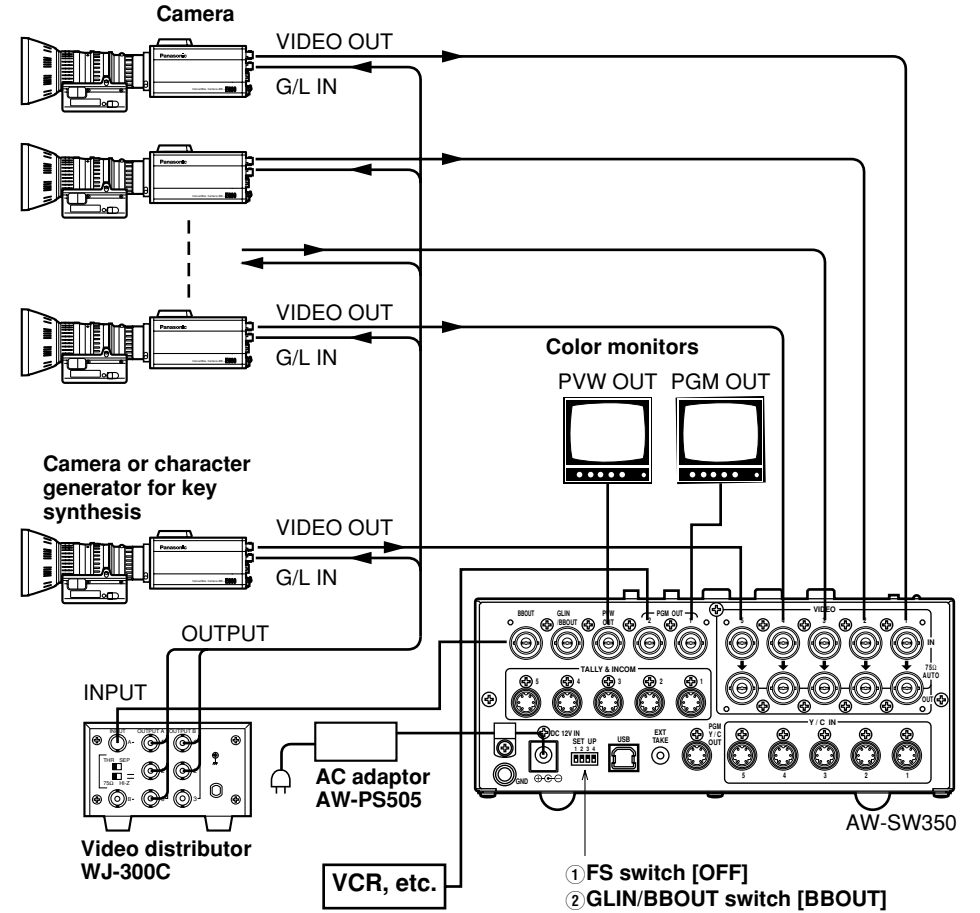

■ CONNECTION TO PERSONAL COMPUTER

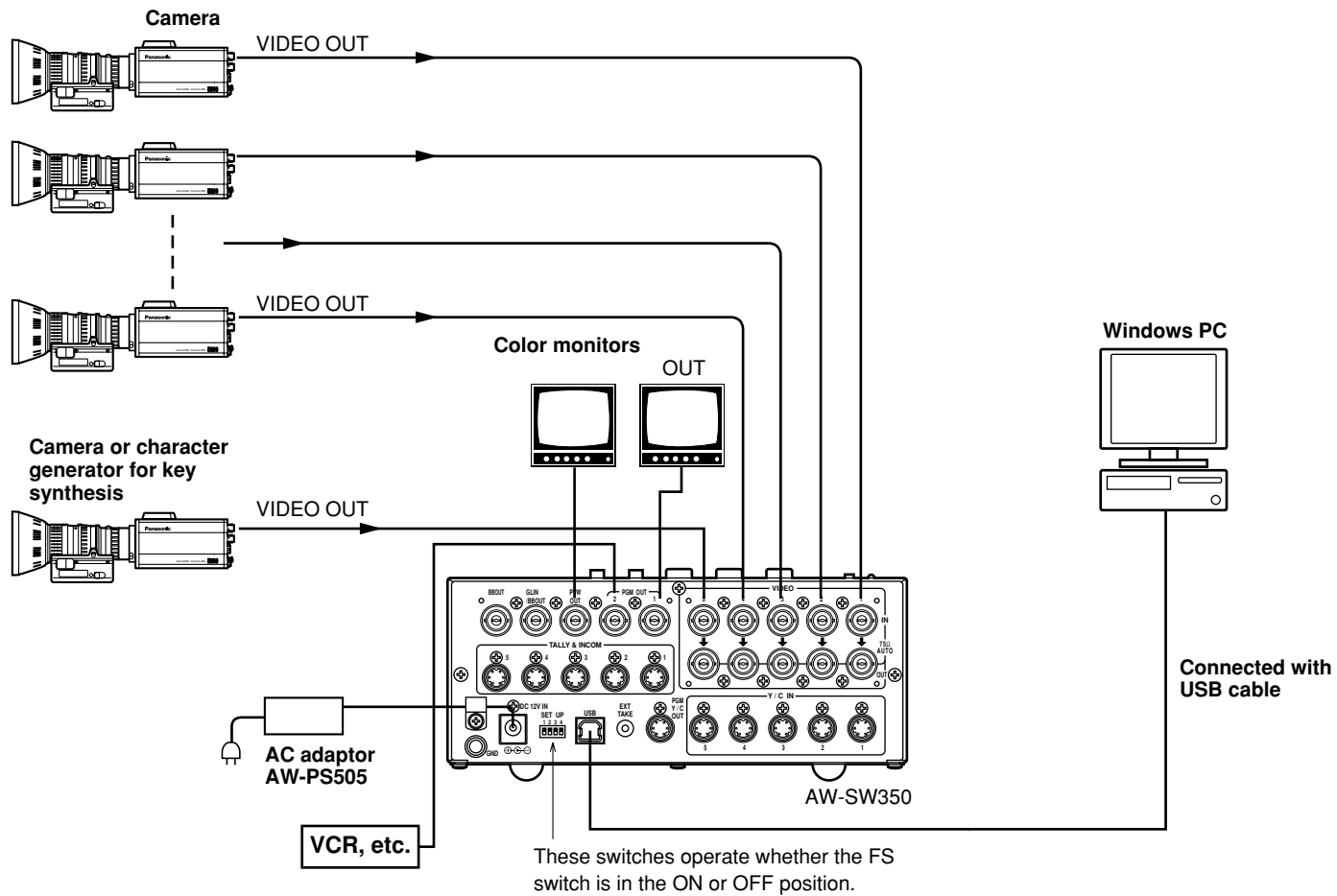

■EXAMPLE FOR THE CONNECTION WITH PAN/TILT HEADS AND CONTROL PANEL

- The cameras can be locally controlled by using the pan/tilt head AW-PH300A, multi-hybrid control panel AW-RP505, and multi-port hub AW-HB505.

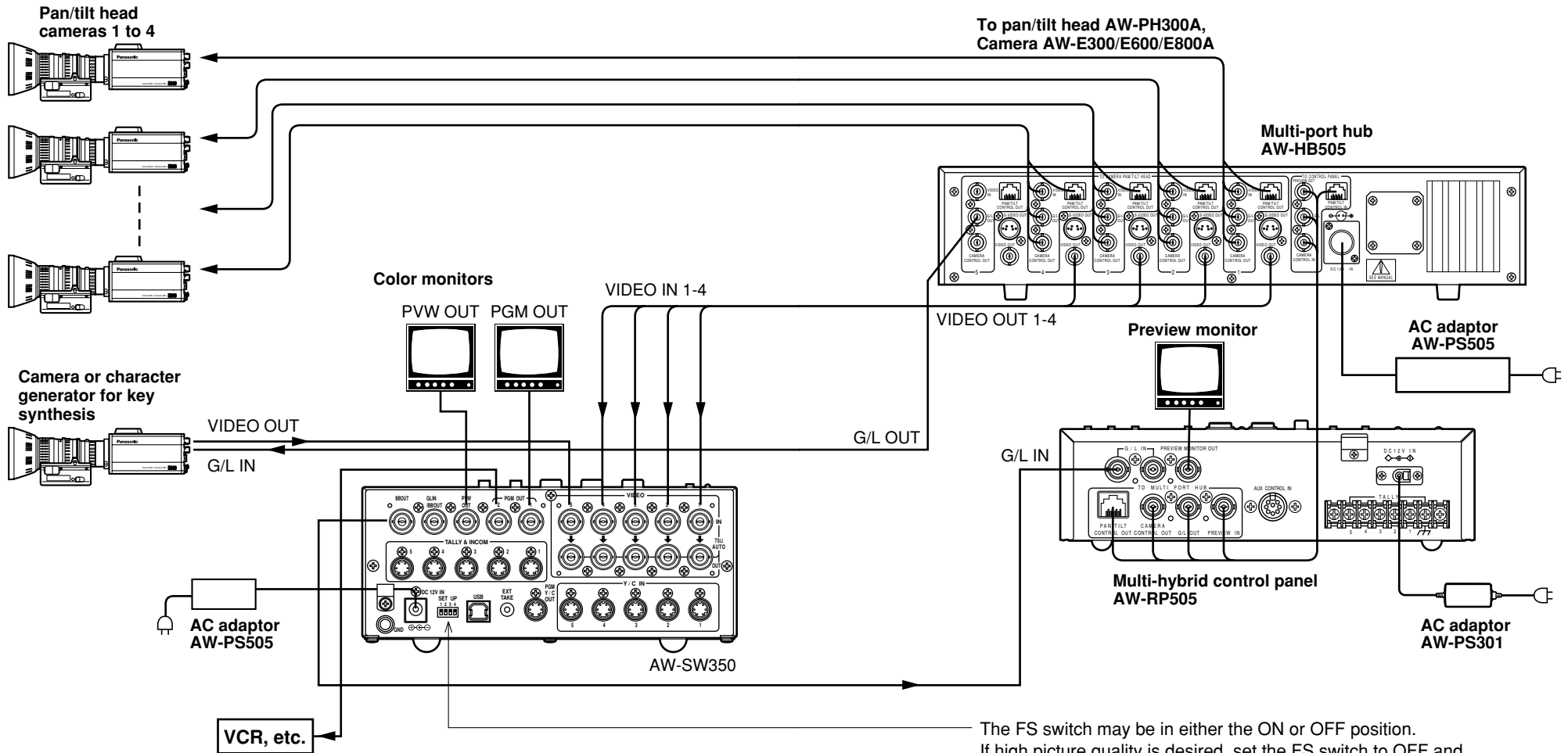

RACK MOUNTING

■ RACK MOUNTING

- Do not mount the Live Switcher on a closed rack or bookshelf.
(Otherwise, heat will build up inside and may cause a fire.)
- Keep the ventilation port open to secure good flow of air.

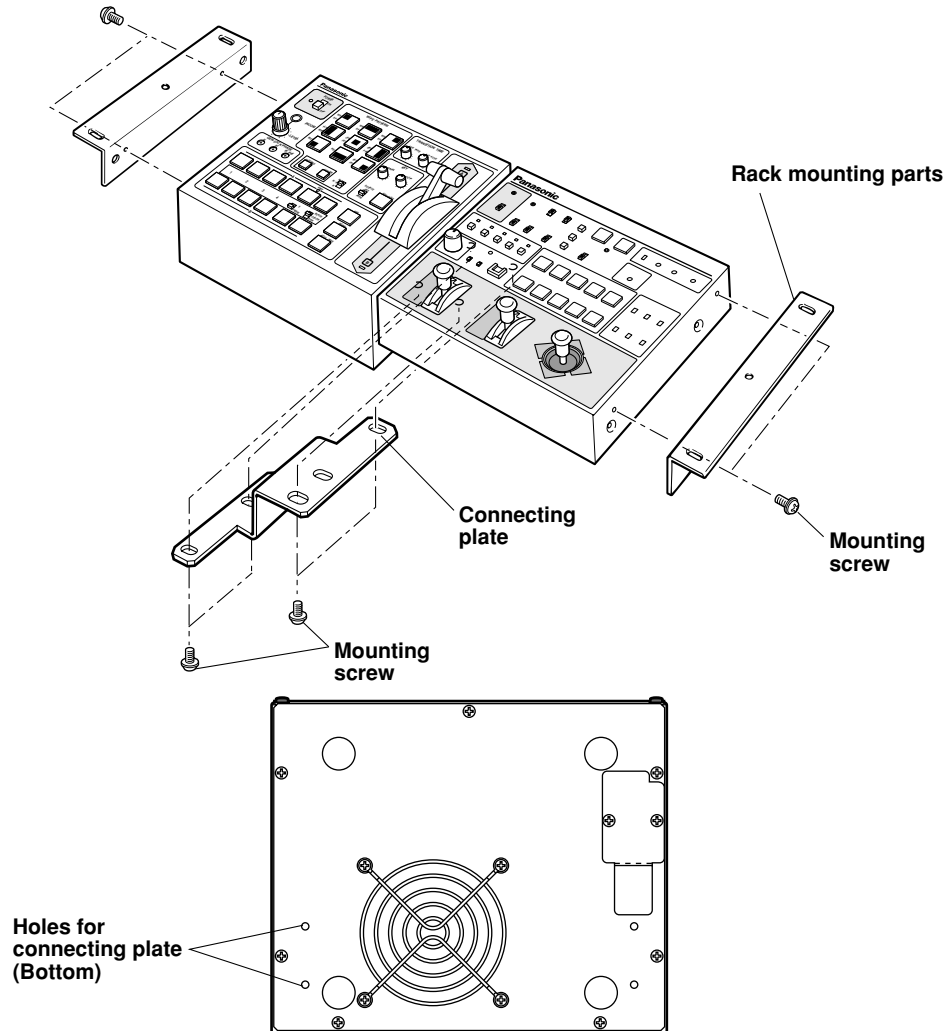

INFORMATION RELATED TO SYSTEM UPGRADES

(1) Switcher phases

- 1) Video signal output phase (frame synchronizer is OFF)

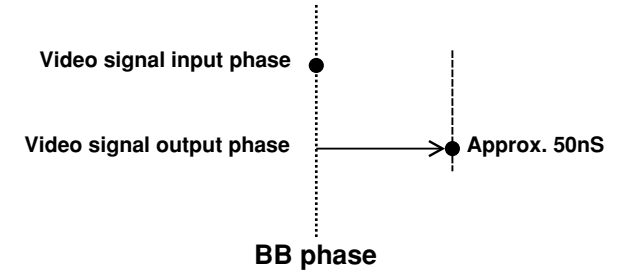

- 2) Video signal input phase (frame synchronizer is ON)

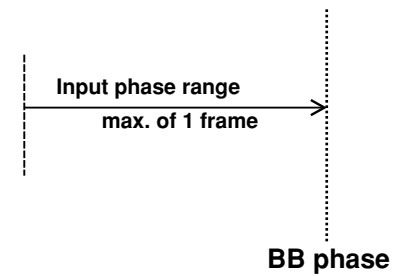

- 3) Genlock adjustment range

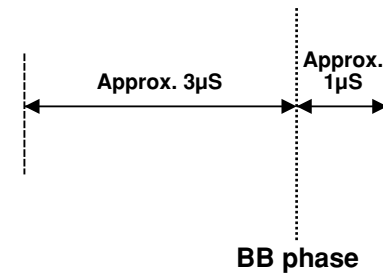

(2) TALLY & INCOM connectors

Use a Mini DIN type 6-pin connector for tally and intercom connections.
(e.g.) TCP8060-01-520 manufactured by Hosiden Corporation

SPECIFICATIONS/STANDARD ACCESSORIES

■ SPECIFICATIONS

Power supply:	12 V DC (+10.8 ~ 16.0V)
Power consumption:	16 W

 indicates safety information.

Video Inputs

Composite video signal:	VBS: 1.0 V[p-p]/75 Ω × 5 (BNC connector, automatic termination)
Y/C:	Y: 1.0 V[p-p]/75 Ω C: 0.286 V[p-p]/75 Ω × 5 (S connector)

Video Outputs

Composite video output:	VBS: 1.0 V[p-p]/75 Ω × 2 (BNC connector)
Y/C:	Y: 1.0 V[p-p]/75 Ω × 1 C: 0.286 V[p-p]/75 Ω × 1 (S connector)
Preview output:	VBS: 1.0 V[p-p]/75 Ω × 1 (BNC connector)
Black burst signal:	BBS: Sync: 0.286 V[p-p], C: 0.286 V[p-p] burst level/75 Ω × 1 (BNC connector)
Signal loopthrough output:	1 each (BNC connector)

Functions and Performance

Frame synchronizer:	10 bit quantization, 13.5MHz sampling Mounted to each channel of VIDEO IN 1 to 5.
Wipe patterns:	9 patterns
Wipe directions:	3 directions (normal, reverse, normal/reverse)
Mix:	Cross fader
Auto take:	Wipe, Mix (time adjustable)
Key synthesis:	Self Key, Linear Key
Intercom:	1 to 5 (6-pin connector, 3/4 wire selectable), Intercom jack (M6 jack)
Tally control:	1 to 5 (open collector output)
Color bar:	Internal (SMPTE, Black/Color selectable)
White and black signals:	Internal
Frequency response:	FS ON: 6.0MHz +1 dB, -3dB FS OFF: 10.0MHz +1 dB, -3dB
S/N:	FS ON: More than 58 dB FS OFF: More than 65 dB
DG/DP:	FS ON: ±2°, ±2% FS OFF: ±1.5°, ±1.5%

Operating temperature range:	32°F to 104°F (0°C to 40°C)
Humidity:	30% to 90%
Dimensions (W × H × D):	8-1/4" × 3-7/16" × 6-15/16" (210 × 86 × 176 mm)
Weight:	Approx. 4.9 lb (2.2 kg)
Finish:	AV ivory painting (Munsell 7.9Y6.8/0.8 or close to it)

Weight and dimensions indicated are approximate.
Specifications are subject to change without notice.

■ STANDARD ACCESSORIES

Tally/intercom connector	5 pcs.
Rack mounting parts	2 pcs.
Connecting plate	1 pc.
Mounting screws	1 set
Image transfer program setup CD	1 pc.

Memo

Panasonic

PANASONIC BROADCAST & TELEVISION SYSTEMS COMPANY
DIVISION OF MATSUSHITA ELECTRIC CORPORATION OF AMERICA

Executive Office:

3330 Cahuenga Blvd W., Los Angeles, CA 90068 (323) 436-3500

EASTERN ZONE:

One Panasonic Way 4E-7, Secaucus, NJ 07094 (201) 348-7621

Southeast Region:

1225 Northbrook Parkway, Ste 1-160, Suwanee, GA 30024 (770) 338-6835

Central Region:

1707 N Randall Road E1-C-1, Elgin, IL 60123 (847) 468-5200

WESTERN ZONE:

3330 Cahuenga Blvd W., Los Angeles, CA 90068 (323) 436-3500

Government Marketing Department:

52 West Gude Drive, Rockville, MD 20850 (301) 738-3840

Broadcast PARTS INFORMATION & ORDERING:

9:00 a.m.–5:00 p.m. (EST) (800) 334-4881/24 Hr. Fax (800) 334-4880

Emergency after hour parts orders (800) 334-4881

TECHNICAL SUPPORT:

Emergency 24 Hour Service (800) 222-0741

Panasonic Canada Inc.

5770 Ambler Drive, Mississauga, Ontario L4W 2T3 (905) 624-5010

Panasonic de Mexico S.A. de C.V.

Av angel Urraza Num. 1209 Col. de Valle 03100 Mexico, D.F. (52) 1 951 2127

Panasonic Sales Company

Division of Matsushita Electric of Puerto Rico Inc.

San Gabriel Industrial Park, 65th Infantry Ave., Km. 9.5, Carolina, Puerto Rico 00630 (787) 750-4300

